

Introduction

Variable capacitance diodes can be very useful in various radio and electronics circuits. The capacitance of a varicap diode decreases with increase of the reverse voltage applied across it. Many radios, TVs and Video recorders are tuned using varicap diodes and they can be cheaper and mechanically simpler to use for the homebrewer than traditional metal plate variable capacitors. The disadvantages are that varicaps generate more noise in oscillators etc, and the capacitance variation is not linearly related to the reverse voltage. With careful design these problems can often be minimised.

While a varicap diode could be useful in many a circuit, they aren't the kind of component you find easily in a junk box. They often



look no different from an ordinary diode or transistor on old circuit boards. If you order them from a component supplier you may have to wait several days for delivery, pay a lot for the component and disproportionately even more for the postage on perhaps this single item. So, realise this: any diode is a varicap diode! The variable capacitance property derives from the fact that as the reverse voltage across the diode increases, the insulation layer between the p-doped semiconductor and the n-doped semiconductor thickens. The effect is similar to separating the two plates of a capacitor by a larger distance, which decreases the capacitance. The only special thing about a varicap diode is that it is specially designed to make this effect as linear and good as possible. In particular if you want a large capacitance at the top of the range, you need a diode with quite a large junction area.

But, I wondered about how ordinary diodes would perform in the place of the varicap diode. I happened to have a BB212 varicap diode, which is a real varicap diode designed for HF and Medium Wave radios. Hence it has quite a large capacitance range. At the time it was sold by

[Maplin Electronics](#)

. This I used for comparison in my experiment. I'd just built a new

[frequency counter](#)

(see picture on the right) and this was also an excuse to make good use of it.

Original varicap diode measurements

Written by Hans Summers

Saturday, 22 August 2009 23:43 - Last Updated Wednesday, 04 January 2012 13:03

Test Circuit

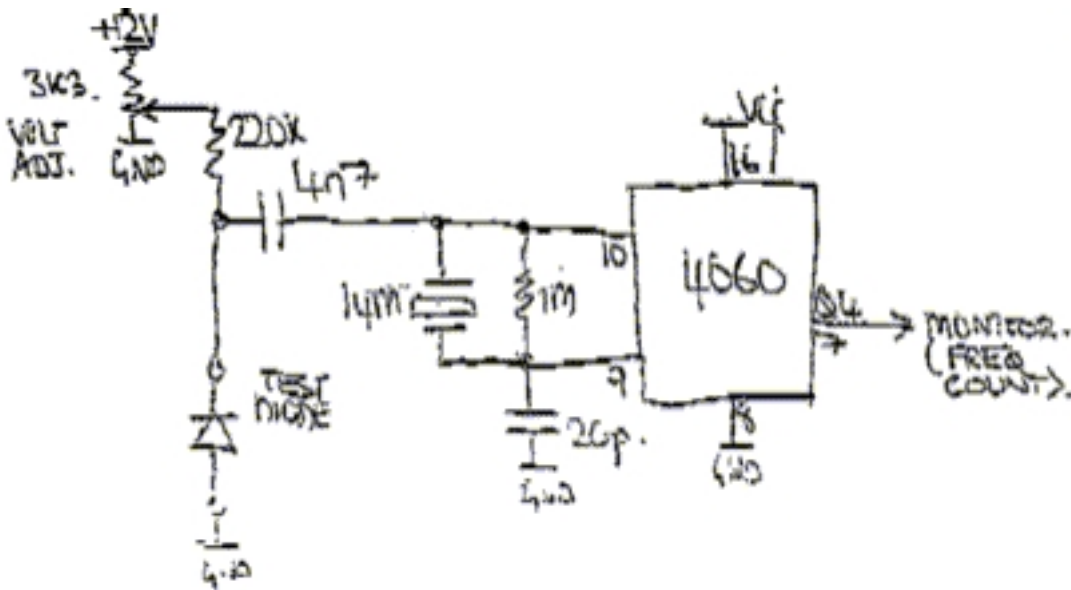

First then, I built this test crystal oscillator using a 14 MHz quartz crystal. The 4060 chip is a binary divider which also includes an on-board oscillator, so its really easy to set up a quick test circuit like this one. The 3K3 variable resistor was used to vary the reverse voltage across the diode under test. In this circuit the additional capacitance of the diode "pulls" the crystal oscillator frequency a small way from its normal 14 MHz frequency. The 4060 produces lots of outputs for various divisions of the 14 MHz frequency. I chose to measure the divide-by-16 output, i.e. 875 KHz. The reverse voltage across the diode was measured using a digital voltmeter.

But before going any further, one has to relate the frequency and voltages measured to the capacitance of the diode. To do this, I collected a number of small ceramic capacitors from my junk box and by desoldering them from various old pieces of equipment that adorn the place. Some of these were capacitances as low as 1 pF (pico-Farad) and by connecting selected components in parallel I could easily obtain a range of known capacitance values. Measuring the frequency and plotting a graph of frequency against known capacitance leads to a nice curve which can be used later to determine the unknown capacitances of the diodes at different reverse voltages, just by reading the frequency and referring to the graph.

Measurement Results

Original varicap diode measurements

Written by Hans Summers

Saturday, 22 August 2009 23:43 - Last Updated Wednesday, 04 January 2012 13:03

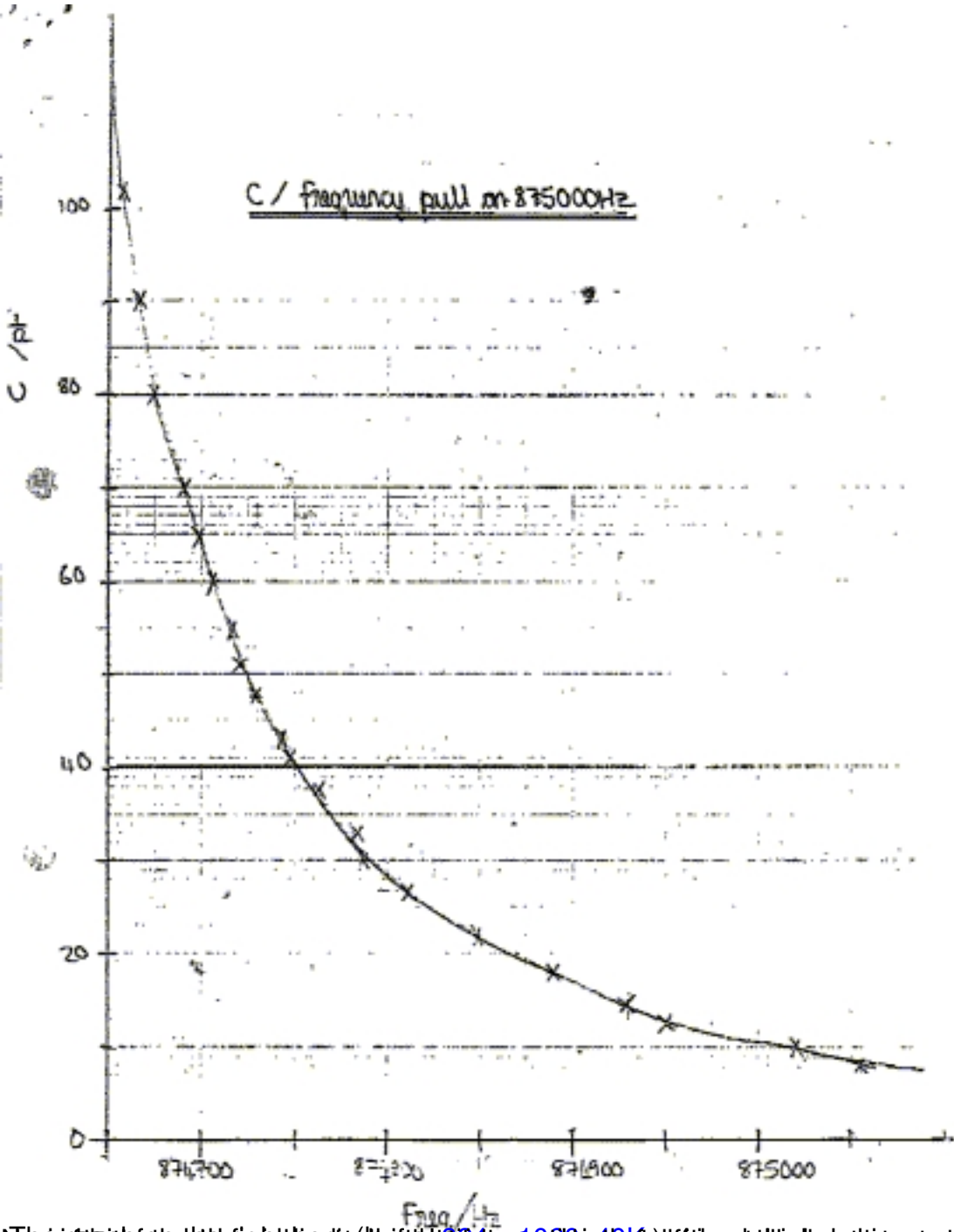

Standard information about this document (http://www.1000.com) is available at the following address: <http://www.1000.com> and high b
CLICK HERE