

LCD Frequency Counter

Written by Hans Summers

Saturday, 05 September 2009 22:31 - Last Updated Sunday, 13 May 2012 13:42

This frequency counter module is intended as a "digital dial" frequency readout for portable QRP radio transceivers. It uses only six standard discrete logic IC's, i.e. no PIC or other microcontroller, no programming to be done, etc. The readout is designed to show kHz from the band edge with 100Hz resolution, i.e. 00.0kHz to 99.9kHz. The display updates ten times per second, which I have found to be a comfortable rate for tuning. The current consumption is 1.4mA, very suitable for portable (battery powered) operation. The size of the counter is 2.3 x 1.6 x 0.8 inches (58 x 41 x 20mm). I included an LED backlight module, which consumes approximately another 100mA (4 LED's, 25mA each). In a battery powered situation, to save power one would probably disable the backlight or have it operate on push-button command only.

{gallery}lcdfreq/1{/gallery}

I also included a x10 mode, which reads 000 to 999kHz from the band edge to 1kHz resolution. Finally, I included a x4 mode, in which the displayed frequency must be multiplied by 4 to get to the actual frequency. The purpose of this mode was to allow both x4 and x10 modes to be used simultaneously, for setting up the transceiver's VFO. In this mode, the counter covers 4MHz of the frequency spectrum to a resolution of 4kHz. Once the VFO is setup correctly, I will probably leave the frequency counter on the intended 100Hz resolution mode.

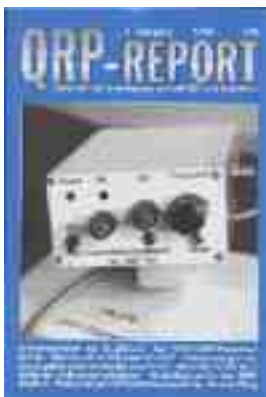

The LCD is direct drive (non multiplexed) and actually has 4 digits, only three of which are used in this application. It would be relatively straightforward to add further IC's to expand the counting range to 4 digits or more, using exactly the same circuit but repeating the circuitry for each digit. Non-multiplexed LCD's are available from [Farnell](#) and [Rapid](#) with matching LED backlights. The LCD has real pins (not elastomer contacts), and is as easy to use as a 40-pin DIP chip.

LCD Frequency Counter

Written by Hans Summers

Saturday, 05 September 2009 22:31 - Last Updated Sunday, 13 May 2012 13:42

Many thanks to [Ingo DK3RED](#) who provided the nice computer drawn circuit diagrams. A German translation of this project will appear in a forthcoming 2006 issue of

[QRP-Report](#)

, the quarterly journal of the

[German QRP club](#)

.

Circuit diagram

{gallery}lcdfreq/circuit{/gallery}

The complete circuit diagram (schematic) is shown above, or [CLICK HERE](#) to open in a new window.

The timebase for this frequency counter uses a 32.000kHz crystal. This is NOT the usual 32.768kHz crystal which is found in clocks and wrist watches by the billion. 32.000kHz crystals are quite hard to find. They are not available in the UK but can be purchased in the US from [Di gikey](#)

or

[Mouser](#)

. 32.768kHz crystals divide

down to 1Hz, but this produces at best a display update rate of once per second, which I find

LCD Frequency Counter

Written by Hans Summers

Saturday, 05 September 2009 22:31 - Last Updated Sunday, 13 May 2012 13:42

too slow for comfortable tuning. 32.000kHz divides to 1000Hz, but this can be further divided to easily create timing for 10 updates per second and 100Hz resolution count, which I consider optimum for this application. The reason I chose such a low frequency crystal rather than a crystal in the MHz range, was twofold. Firstly, the lower frequencies require less division, which means lower parts count (in this instance it is all done within a single 74HC4060). Secondly, current consumption. The lower frequency crystal oscillators consume only some 30uA of current, compared to 3mA for a 4MHz crystal for example. I wanted to keep the overall current consumption of the frequency counter as low as possible.

The diagram to the right shows the timing cycle used in this frequency counter. The spare half of the 74HC390 dual decade counter IC6a generates the timing from the 100Hz output of the 74HC4060 which is designed to reset at a count (division ratio) of 320. Each cycle lasts 0.1 seconds and consists of an effective count gate of 0.01 seconds, followed by a latch signal to the display decoder/drivers, and then a reset pulse to the counters in preparation for the next counting period.

It was very simple to create this timing arrangement using only diodes and resistors. The basic setup requires only 5 diodes. An additional six diodes are shown at the IC4 outputs and they further reduce the gate period by a factor of 4 and 10 when the links LK1 and LK2 are closed, respectively. If these modes were required to be available to the operator they could be selected using toggle switches, which could also extinguish the decimal point (for example, in 000 - 999kHz mode).

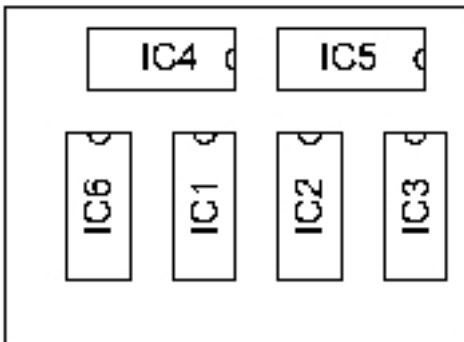

Note that unused segments (digit 4 in my case) and decimal points of the LCD should be connected to its backplane. The backplane is driven by a 50Hz squarewave output from IC6a. This signal also drives the phasing input to IC's 1 to 3, which are BCD to 7-segment LCD drivers. The LED backlight consists of four green LED's, rated at 25mA current consumption each. I found that 15 ohms to 5V for each LED produced about the right current level. In some applications, for example if the 5V was regulated from a 12V battery powering the transceiver, it may be more efficient to connect the LED's in two or one series chain rather than in parallel across the regulated supply.

The IC layout is shown to the right. The IC's are mounted on one piece of matrix board sized 1.6 x 1.3 inches. The LCD is mounted on an identical piece of matrix board. The LED backlight is sandwiched in between the LCD and the board. The LCD board and the IC board are hinged

LCD Frequency Counter

Written by Hans Summers

Saturday, 05 September 2009 22:31 - Last Updated Sunday, 13 May 2012 13:42

along one edge by the necessary wired connections. When soldering was complete, the two sides folded over to produce a compact double-deck arrangement.

Photographs (click the thumbnails for larger images)

 **LCD with backlight operational:**

The displayed frequency of 32.0kHz is the unit reading its own crystal reference frequency. The input w

 **LCD without backlight:**

Here's the LCD without the LED backlight. The light is probably an unnecessary luxury and certainly an

 **Closeup of readout:**

A nice closeup of the 32.0 readout. Beautifully clear!

 **Boards hinged open:**

Here you can see the two boards hinged open, revealing the IC's and the back of the LCD. Note the con

 **Top view:**

Showing the LED's of the backlight and the IC's (IC4 and IC5). The two soldered wires in the corners ho

 **Bottom view:**

Showing the wires of the "hinge".

 **Back view:**

Here's the real shocker [AC Compact 675KHz](#) function, going crazy, the crystal from the US. The diodes in a pile und